

tyco

Flow Control

Tyco Water

SUPERCHECK Resilient Seated swing check valves unique design enables faster closing with reduced water hammer.

Features

- Ductile Iron body and cover for high strength and impact resistance
- Ductile Iron components are fusion coated with Rilsan Nylon 11 for long life corrosion protection
- Full bore design for minimum head loss
- No debris pockets
- Disc held in open position by positive pressure to avoid fluctuations
- Free acting and counterweight versions available. Interchangeable in the field
- Limit switch fit out available.
- Free acting version features EPDM encapsulated gunmetal disc with pressure activated lip seal and fully flexible rubber hinge
- Counterweight version features EPDM encapsulated gunmetal disc with pressure activated lip seal and solid stainless steel shaft
- Counterweight utilises separate shaft located in the cover to enable rapid closing and lessen fluctuations
- Adjustable counterweight can be mounted on either side of the valve
- Integral body seat for maintenance free operation
- Integral cast feet for safe and easy storage
- Counterweight shaft seals are O-Ring type to ensure leak free operation
- Isolated fasteners for corrosion protection
- Slotted holes on top of inlet flange to facilitate bolt insertion when connecting to adjacent valves



General Application

Swing check valves are suitable for water and wastewater applications. Used to prevent backflow within a pipeline.

Technical Data

Size Range: DN100 - DN150
Allowable Operating Pressure: 1600 kPa
Minimum Flow: 1.4 m/s
End Connections: Flanged to AS 4087 Figure B5
Standards: AS 4794 - Non-Return Valves For Waterworks Purposes
Certifications: Certified to AS 4020 - Suitable for contact with drinking water.

SUPERCHECK Swing Check Valves

Resilient Seat DN100 - DN150

Free Acting Swing Check Valve

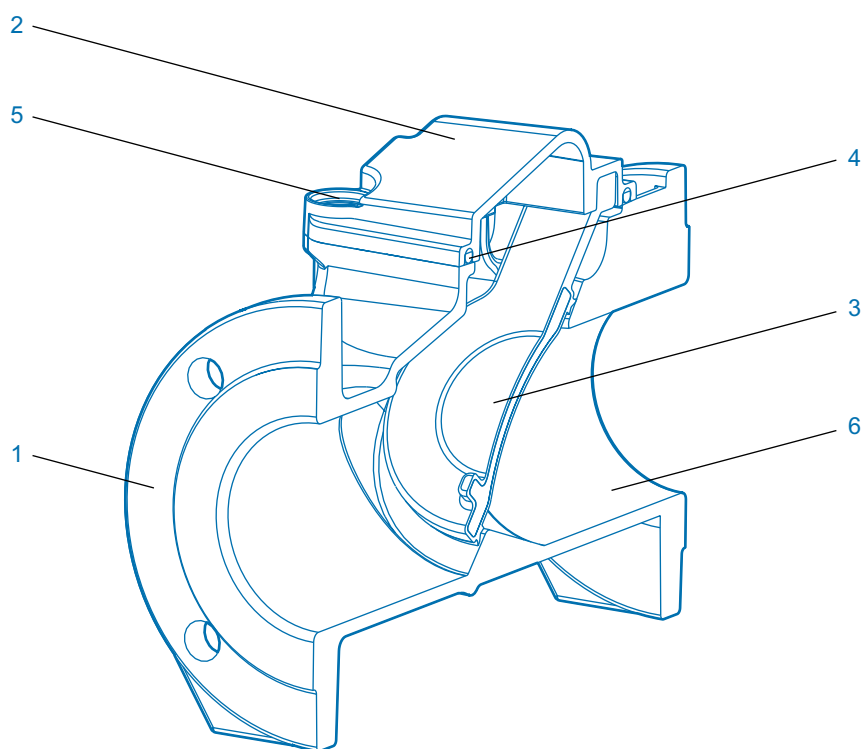

Parts List

No	Description	Material	Standard
1	Body	Ductile Iron	AS 1831-400/15
2	Cover	Ductile Iron	AS 1831-400/15
3	Disc Flexible	Gun Metal (EPDM coated)	AS 1565 C83600
4	Gasket	EPDM	AS 1646
5	Countersunk Screws	High Tensile Alloy Steel	-
6	Coating	Rilsan Nylon 11	AS/NZS 4158

Dimensions (mm)

DN	Length	Width	Height
100	330	215	254
150	410	329	343

SUPERCHECK Swing Check Valves

Resilient Seat DN100 - DN150

Counterweight Swing Check Valve

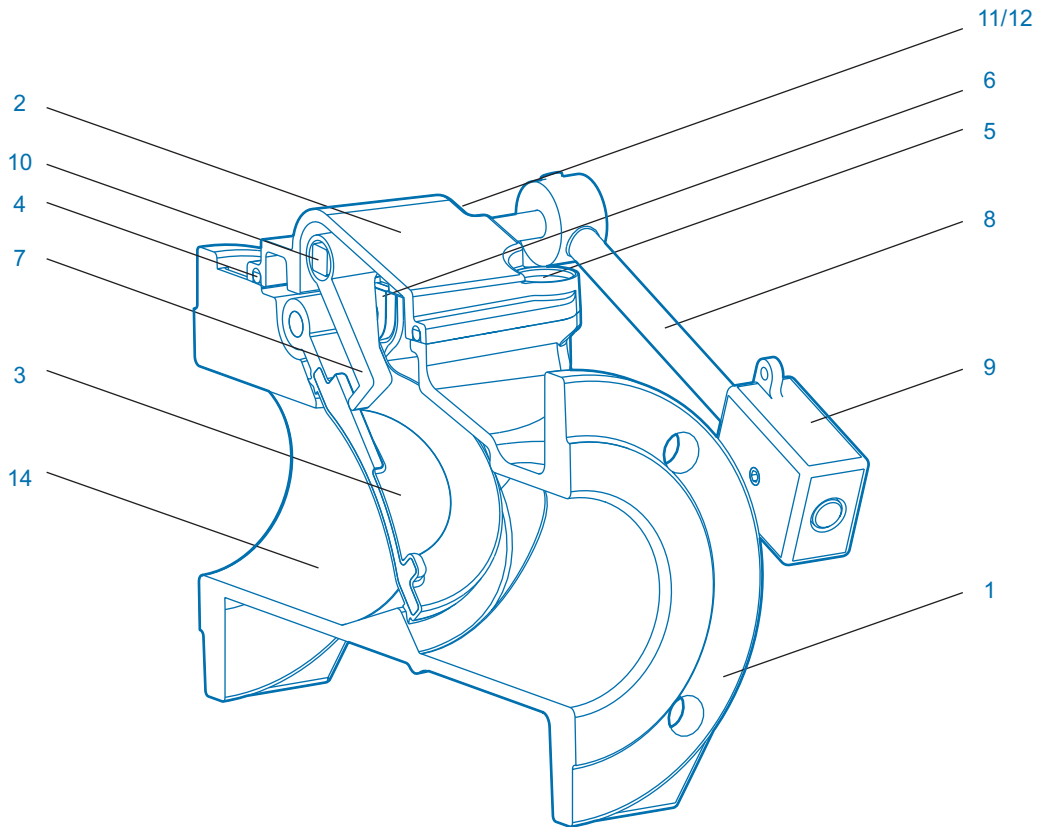

Parts List

No	Description	Material	Standard
1	Body	Ductile Iron	AS 1831-400/15
2	Cover	Ductile Iron	AS 1831-400/15
3	Disc hinged	Gun Metal (EPDM coated)	AS 1565 C83600
4	Gasket	EPDM	AS 1646
5	Countersunk Screws	High Tensile Alloy Steel	-
6	Hinge Bush	Gunmetal	AS 1565 C83600
7	Anvil	Gunmetal	AS 1565 C83600
8	Lever	Stainless steel	ASTM A240-316
9	Weight	Ductile Iron	AS 1831-400/15
10	Shaft	Stainless Steel	ASTM A276-431
11	Bush - Hollow (hidden)	Gunmetal	AS 1565 C83600
12	O-rings (hidden)	Nitrile Rubber	AS 1646
13	Bush - Blank (not shown)	Gunmetal	AS 1565 C83600
14	Coating	Rilsan Nylon 11	AS/NZS 4158

Dimensions (mm)

DN	Length	Width	Height
100	330	269	254
150	410	340	343

SUPERCHECK Swing Check Valves

Resilient Seat DN100 - DN150

Typical Specifying Sequence

Specifying a DN150 free acting, resilient seated check valve with AS 4087 Figure B5 flanges

Example	150	RS CHK VLV	TC	FA	FC
Nominal Size					
Item Type Resilient Seat Check Valve					
End Type Flanged - AS 4087 Figure B5					
Action FA - Frees Acting CWT - Counterweight					
Extra Information FC - Fusion Coated					

Recommended Specification

- Swing check valves shall be resilient seated conforming to AS 4794.
- The allowable operating pressure shall be 1600kPa
- Disc shall be fully open at a velocity of 1.4m/s.
- The valve body and cover shall be cast in Ductile Iron and coated with a thermally applied polymeric coating to AS/NZS 4158
- The disc shall be encapsulated in EPDM rubber to AS 1646.
- Fasteners shall be completely isolated from the external environment.

Where a lever and weight is required :

- The counterweight shaft seal shall be affected by a minimum of two O-rings.
- The disc hinge pin and counterweight shaft shall be separate to facilitate rapid closing of the disc.
- The lever shall be grade 316 stainless steel to ASTM A240.
- The weight shall be ductile iron coated with a thermally applied polymeric coating conforming to AS/NZS 4158