

tyco
Water

SUREFLOW[®] Spring Hydrant Valves

SUREFLOW spring hydrant valves are designed and manufactured to AS 3952. DN 80 and DN 100

- Ductile Iron body and yoke for high strength and impact resistance
- Dezincification resistant (DZR) copper alloy dome for long life operation.
- Removable internal components to allow direct full bore access to the pipeline for insertion and removal of swabs for scouring purposes
- Extra thick seat gasket to provide improved perforation resistance and reduced maintenance requirements
- Thermal bonded polymeric coating for long life corrosion protection
- Corrosion resistant components for long life operation
- O-ring located on fasteners to ensure they remain in place when the yoke is removed
- Dust cap fitted to each hydrant to prevent ingress of dirt into the seat area
- Lilac, colour coded model for recycled water application
- Lilac, colour coded tags for retro fitting or simplicity of stock control



SHAC010S7



SHAC008S7L

General application

SUREFLOW Spring Hydrant Valves provide direct access to water pipelines for fire fighting purposes. Access is gained by the attachment of a standpipe to the hydrant lugs. The hydrant valve can also be used as a scouring or flushing point.

Technical data

Allowable Operating Pressure:
1600 kPa

Seat Infiltration Resistance:
55 kPa (vacuum)

Maximum Temperature:
40°C

End Connections:
Flanged to AS 4087 Fig B5,
DN 80 and DN 100

Certification:
ISC Product Mark Licence No.
PRD/R61/0412
AS 4020 - suitable for contact with
drinking water.

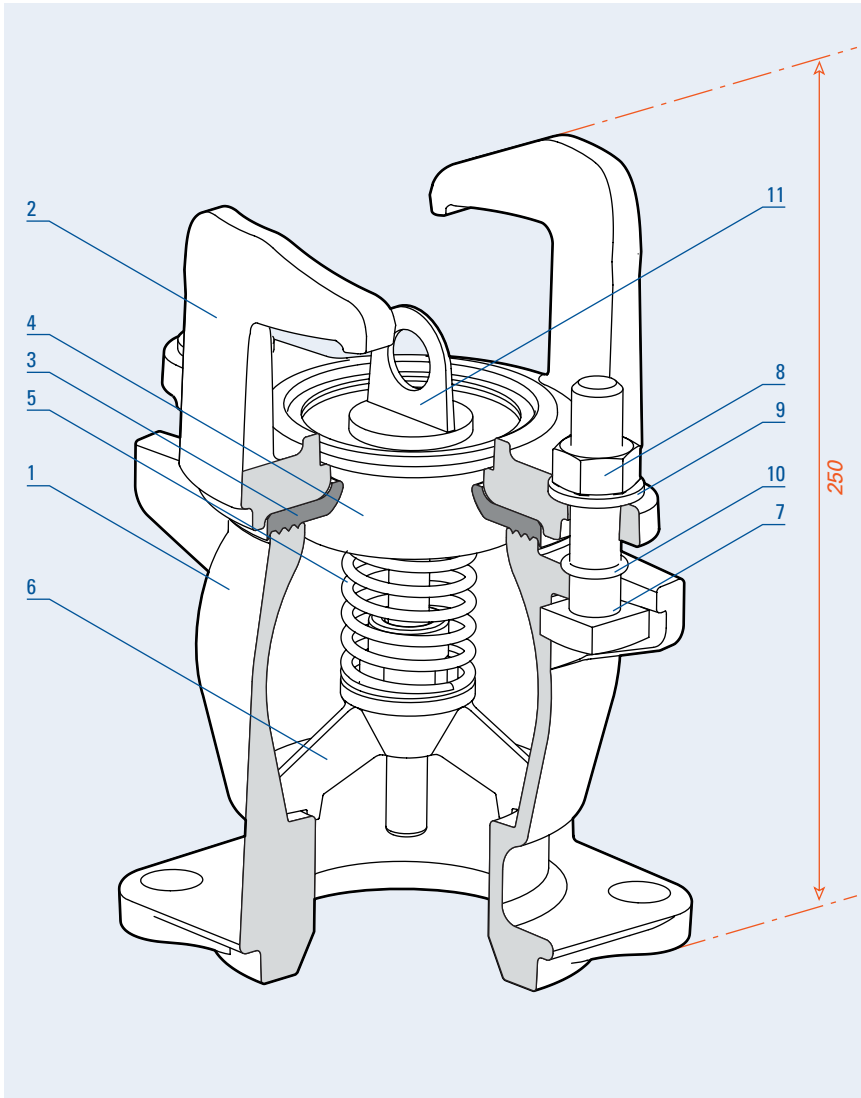

SUREFLOW Spring Hydrant Valve parts list

No	Description Material / Standard
1	Body Ductile Iron / AS 1831 400-15
2	Yoke Ductile Iron / AS 1831 400-15
3	Gasket EPDM rubber / AS 1646
4	Dome DR copper alloy / AS 1568 C48600
5	Spring Stainless steel / ASTM A276 304
6	Spring support Stainless steel / ASTM A276 304
7	Bolt Stainless steel / ASTM A276 316
8	Nut Stainless steel / ASTM A276 316
9	Washer Stainless steel / ASTM A276 316
10	O-ring Nitrile rubber / AS 1646
11	Dust cap UV stabilised polyethylene

Recycled water identification options

Hydrant with
lilac coated lugs



Lilac, recycled
water hydrant tags
to suit standard
hydrants



SUREFLOW Spring Hydrant Valves

Nominal size DN	Product code	Weight kg
-----------------------	-----------------	--------------

SUREFLOW Spring Hydrant Valves

80	SHAC008S7	8.5
100	SHAC010S7	9.5

SUREFLOW Spring Hydrant Valves with lilac coated lugs

80	SHAC008S7L	8.5
100	SHAC010S7L	9.5

Lilac, recycled water hydrant tags

SHTAGLILAC