

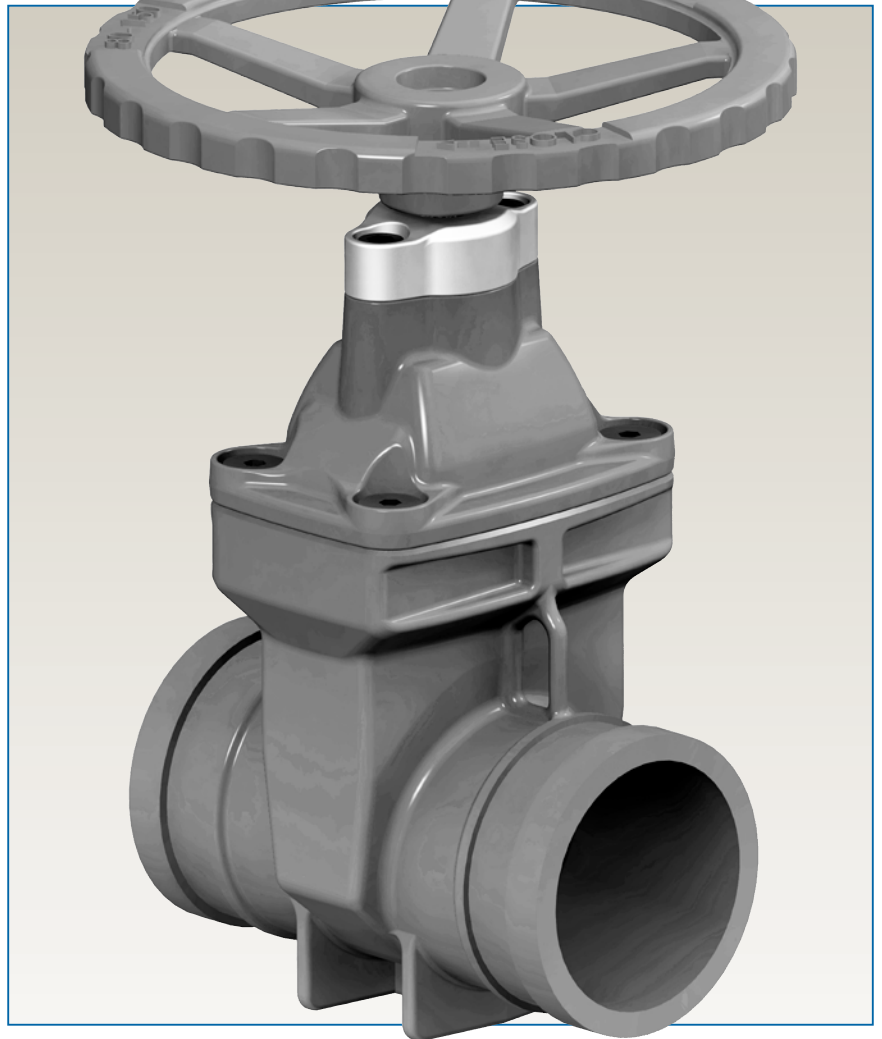

These AUSLITE Resilient Seated Gate Valves, with shouldered ends, feature a non-rising spindle. Designed and manufactured to AS 2638.2.

Feature

- Ductile Iron body and bonnet for high strength and impact resistance.
- Ductile Iron gate fully encapsulated in EPDM rubber to ensure drop tight sealing.
- Grade 431 stainless steel spindle for high strength and corrosion resistance.
- Dezincification resistant copper alloy seal housing incorporating dual O-ring seals and wiper ring for long life operation.
- Back seal facility to allow for replacement of seals under full operating pressure.
- Fusion bonded epoxy coating for long life corrosion protection.
- Straight through full bore to avoid debris traps.
- Isolated fasteners for corrosion protection.
- Anti-friction guide liners for low operating torques.
- Integral cast-in feet for safe and easy storage.
- Integral lifting lugs for installation convenience.
- Anticlockwise closing or clockwise closing available.
- Key or hand wheel operation available.



General Application

AUSLITE Resilient Seated Gate Valves with shouldered spigot ends are commonly used in mining and fire service applications

Technical Data

Size Range:

DN 100 and DN 150

Allowable Operating Pressure:
2500kPa

Maximum Temperature:
40°C

End Connections:
Shouldered spigot

Certifications:
AS 2638.2 – Gate valves for waterworks purposes.
Product Mark Registration
No. PRD/R61/0412/2

Resilient Seated Gate Valves – Shouldered Ends DN 100 and DN 150

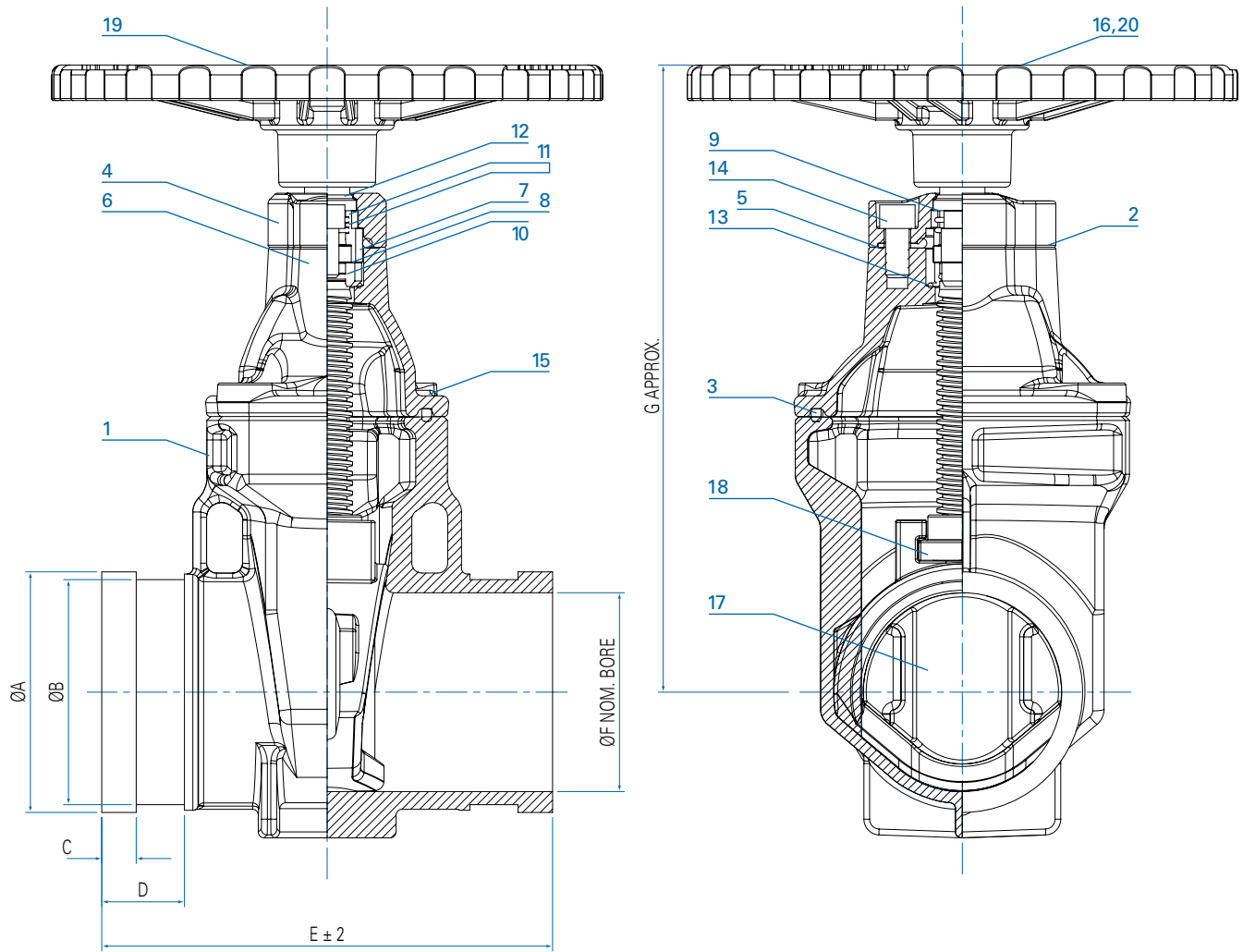

Parts List

No	Description	Quantity	Material	Standard
1	Body	1	SGI	AS 1831/400-15
2	Bonnet	1	SGI	AS 1831/400-15
3	Body Gasket	1	EPDM	AS 1646/70IRHD
4	Retaining Plate	1	SS	AS 2837/316
5	Top Gasket	1	EPDM	AS 1646/DURO 70-75
6	Stem	1	SS	ASTM A276/431
7	Collet Set	1	DZR	AS 1567/C35200 or C48600
8	Backseal Collar	1	DZR	AS 1567/C35200 or C48600
9	Seal Housing Bush	1	DZR	AS 1567/C35200 or C48600
10	O-Ring	1	NBR	AS 1646/70 DURO
11	O-Ring	2	NBR	AS 1646/70 DURO
12	Wiper Ring	1	NBR	AS 1646/70 DURO
13	O-Ring	1	NBR	AS 1646/70 DURO
14	Cap Screw	2	CS	AS 1252/12.9
15	Countersunk Screw	4	CS	AS 1252/12.9
16	Hex Head Screw	1	SS	ASTM A276/316
17	Wedge	1	SGI	AS1831/400-15 – EPDM Coating
18	Wedge Nut	1	DZR	AS 1567/C35200 or C48600
19	Handwheel	1	SGI	AS 1831/400-15
20	Extra Large Washer	1	SS	ASTM A276/316

Recommended Specification

- Gate valves shall be resilient seated conforming to AS 2638.2.
- The allowable operating pressure shall be 2500kPa.
- Operation shall be by means of a handwheel.
- The direction of closing shall be clockwise.
- The valve body and bonnet shall be cast in Ductile Iron and coated with a thermally applied polymeric coating to AS/NZS 4158.
- The gate shall be cast in Ductile Iron and fully encapsulated in EPDM rubber – partially coated wedges are not acceptable.
- The spindle shall be Grade 431 Stainless Steel incorporating a failsafe thrust collar.
- The spindle seal retainer shall be manufactured from a dezincification resistant copper alloy to AS 1567.
- A spindle wiper seal shall be fitted to the spindle to prevent ingress of dirt and foreign matter.
- The spindle seal shall be effected by a minimum of two o-rings, which can be replaced under full operating pressure.
- Fasteners shall be completely isolated from the external environment.
- Valves shall be manufactured under a product certification scheme and each valve marked in accordance with the certification body's requirements.

Dimensions

	A	B	C	D	E	F	G	Mass kg	Turns to Seal	Torque to Seal. N/m
DN 100	122.2	114.3	17.5	42	229	101	320	15	21	40
DN 150	175.1	165.1	17.5	56	267	151	395	20	32	60