

Valve Anchor Kit

To suit DN100 & DN150 Socketed Gate Valves



Easy to install valve thrust restraint system.

Features

- Ductile Iron Anchors for strength and impact resistance
- Simply attached to Socketed Gate Valve.
- 316 Stainless Steel bolts, nuts & washers.
- Easily installed into pipeline.
- Thermally bonded polymeric coating for long life corrosion protection.

Anchor Kit Components

- Two Anchors
- Two M16 Bolts
- Four M16 Washers
- Two M16 Nuts

General Application

Used for restraining thrust on Socketed in-line Gate Valves

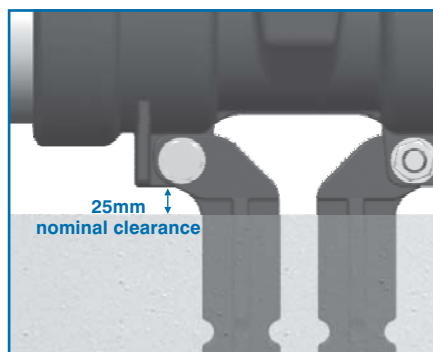
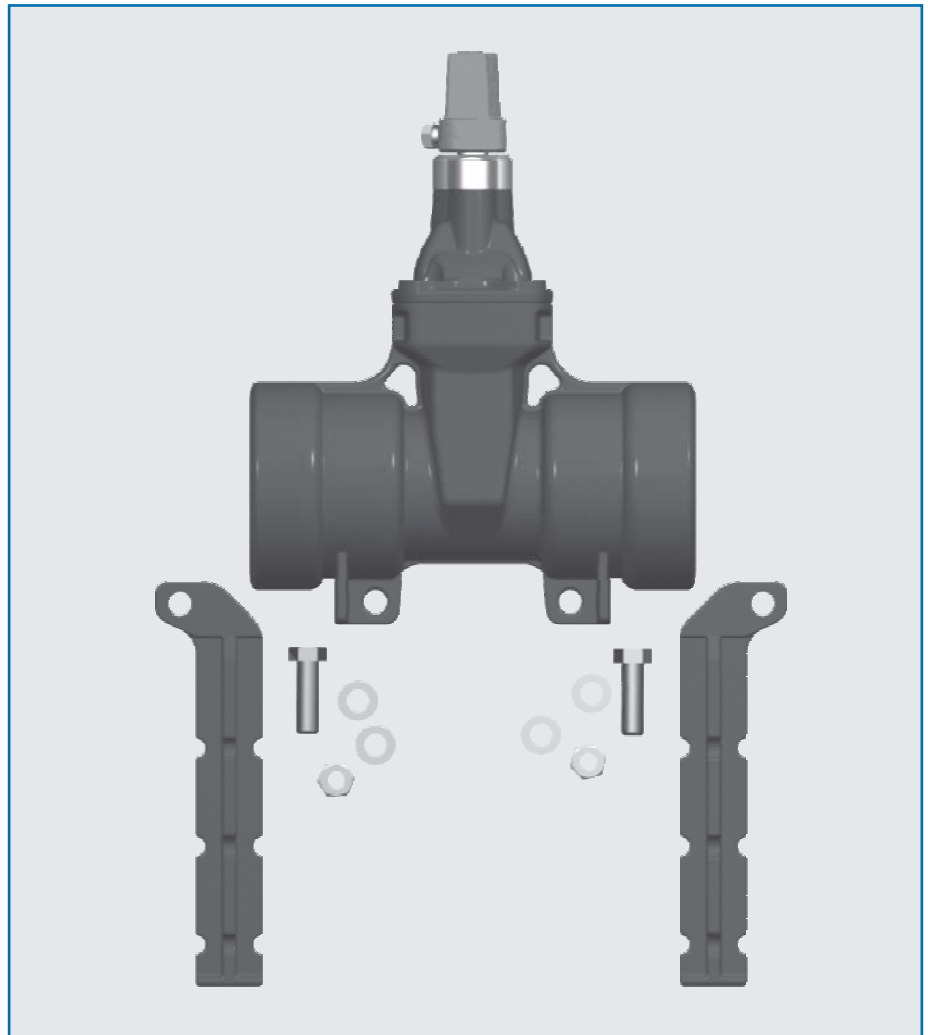
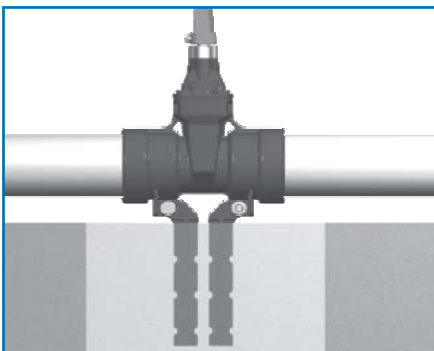
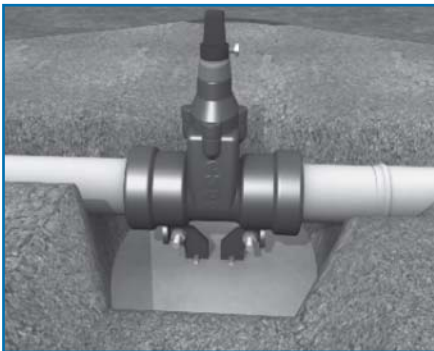

Technical Data

Size Range: DN100 & DN150

Allowable Operating Pressure: 1600 kPa

Maximum Site Test Pressure: 2000 kPa

Concrete Thrust Block: Thrust block should be designed to suit local requirements & soil conditions.

Anchor Leg Depth: We recommend filling concrete to corner of anchor leg as a minimum. As displayed in diagram.